

1 (a) Define the term *excretion*.

.....

.....

.....

.....

..... [3]

Fig. 2.1 shows a dialysis machine for treating people who have kidney failure. The dialysate (dialysis fluid) is a solution of glucose and salts.

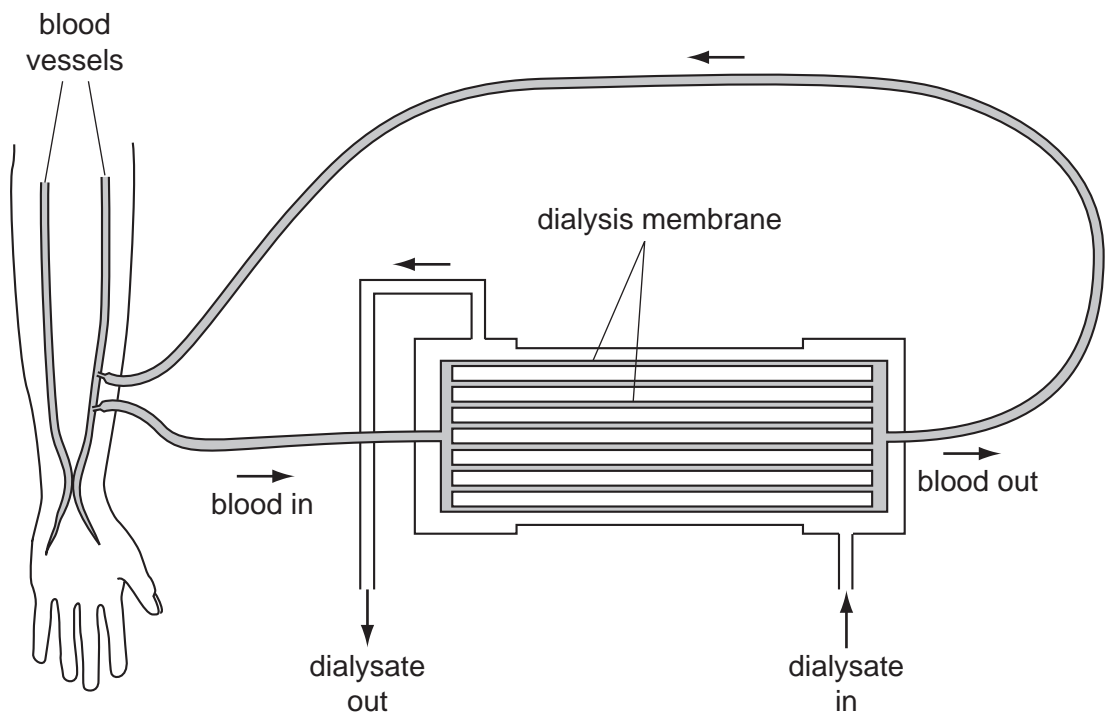

Fig. 2.1

(b) Explain how, when the patient is receiving dialysis treatment

(i) the loss of plasma proteins and red blood cells is prevented,

.....

..... [1]

(ii) the normal glucose concentration of the blood is maintained.

.....

.....

.....

..... [2]

(c) A person with kidney failure received regular dialysis treatment for 17 days.

Fig. 2.2 shows how the concentration of urea in the blood changed over the 17 days.

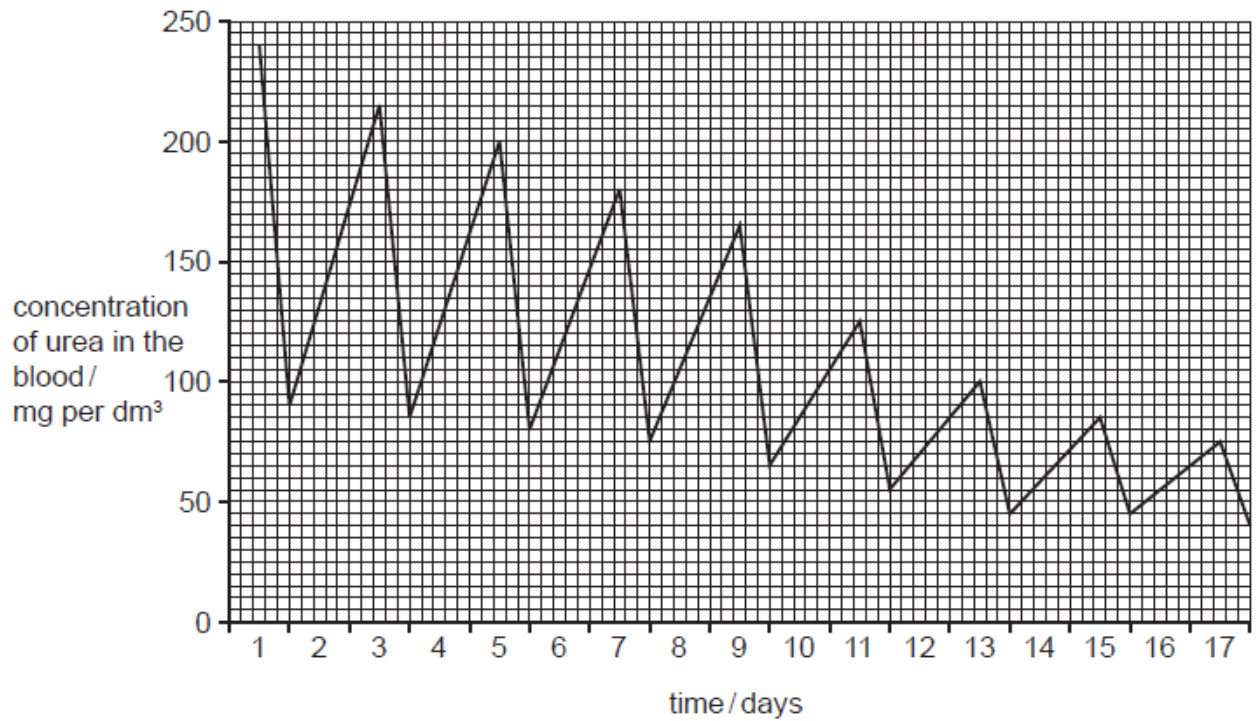

**Fig. 2.2**

(i) State how many times the person received dialysis treatment.

..... [1]

(ii) Calculate the decrease in the concentration of urea in the blood from the beginning of dialysis until the end of the treatment.

..... [1]

(iii) Describe the changes that occur in the urea concentration in the blood over the period shown in Fig. 2.2. You will gain credit for using the data in Fig. 2.2 in your answer.

.....

.....

.....

.....

.....

..... [3]

(iv) Explain the changes in urea concentration in the blood as shown in Fig. 2.2.

.....

.....

.....

.....

.....

.....

..... [4]

[Total: 15]

2 To stay healthy we need a balanced diet.

(a) Define the term *balanced diet*.

.....  
.....  
..... [2]

Protein is one nutrient present in a balanced diet. The body cannot store protein, so any excess amino acids are broken down in the process of deamination, as shown in Fig. 5.1.

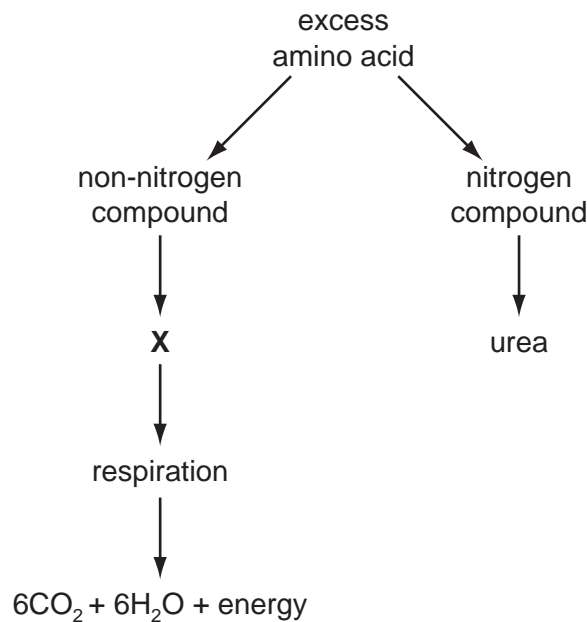

Fig. 5.1

(b) Name the organ where deamination takes place.

..... [1]

(ii) Compound **X** is used as an energy source in respiration.

Suggest the name of compound **X**.

..... [1]

(iii) State the type of respiration shown in Fig. 5.1.

Explain your answer.

type of respiration .....

explanation .....

..... [2]

(c) The urea produced is transported to the kidney, where it is excreted.

Describe how urea is transported in the blood to the kidney.

.....

..... [2]

Fig. 5.2 shows a kidney tubule (nephron) and its associated blood vessels.

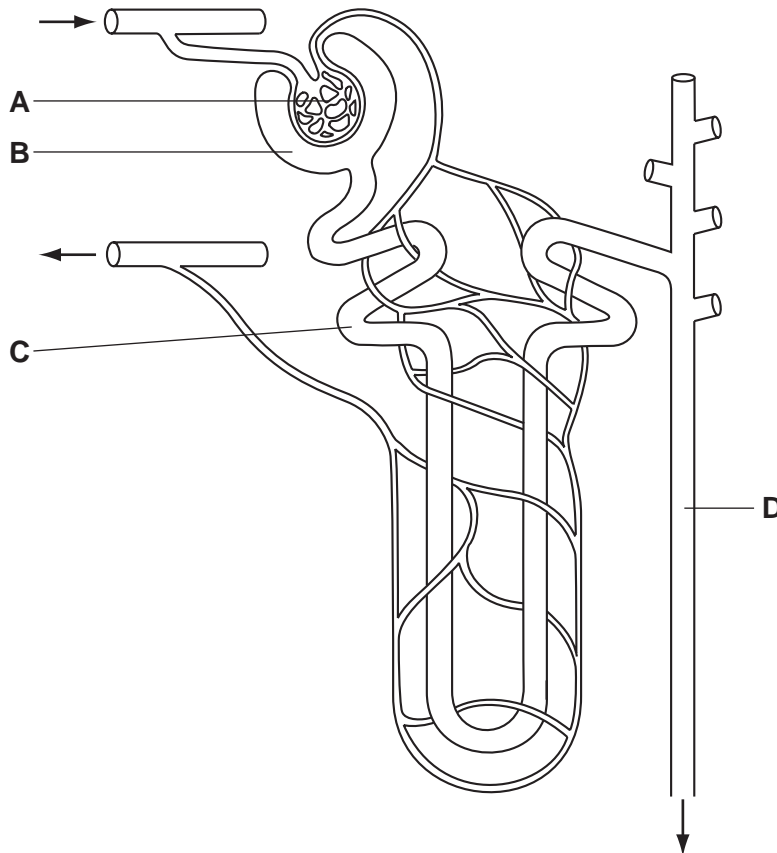

Fig. 5.2

(d) Complete the table by naming the parts labelled **A** to **D** and stating **one** function for each.

	name of part	function
<b>A</b>	..... .....	..... ..... .....
<b>B</b>	..... .....	..... ..... .....
<b>C</b>	..... .....	..... ..... .....
<b>D</b>	..... .....	..... ..... .....

[8]

(e) The volume of blood filtered by the kidneys is  $1.18 \text{ dm}^3 \text{ min}^{-1}$ .

(i) Calculate the total volume of blood filtered in 24 hours.

Show your working.

volume = ..... [2]

(ii) If the total volume of urine produced in 24 hours is  $1.7 \text{ dm}^3$ , calculate the percentage volume of the filtered blood excreted as urine in 24 hours.

Show your working.

% volume = ..... [2]

[Total: 20]

3 (a) Define the term *excretion*.

.....

.....

.....

..... [3]

(b) Fig. 3.1 shows a section through a kidney.

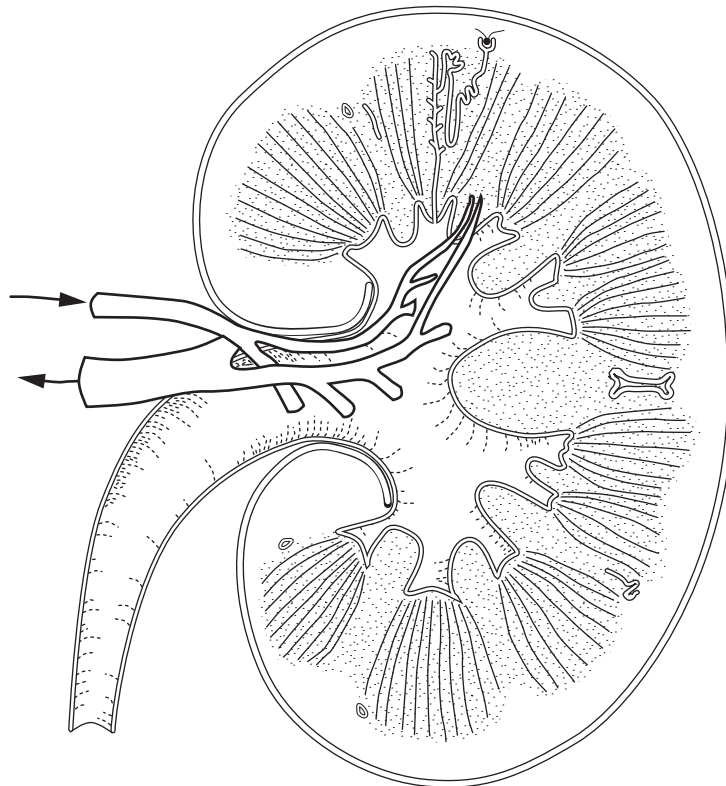

**Fig. 3.1**

(i) Using label lines and the letters given, label the following on Fig. 3.1.

**F** where filtration occurs,

**R** the renal artery,

**U** where urine passes to the bladder.

[3]



(ii) Describe the process of filtration in the kidney.

.....  
.....  
.....  
..... [3]

(iii) Name the processes resulting in the reabsorption of

1. glucos .....  
2. wate ..... [3]

[Total: 12]